



8W Mono Class- F Audio Amplifier With EQ Function

General Description

The LPA2173 is a 8W, class-F audio amplifier with a mode pin for switch the work mode. It offers low THD+N, allowing it to achieve high-quality Power Supply sound reproduction. The new filterless architecture allows the device to drive the speaker directly requiring no low-pass output filters, thus to save the system cost and PCB area. The LPA2173 is available in ESOP-8.

Order Information

LPA2173 □ □ □

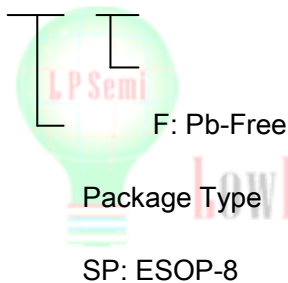

Features

- ◆ Shutdown current:<3uA
- ◆ 500KHz fixed frequency switching for amplifier
- ◆ 8W Output at 10% THD with a 2Ω Load and 6.0V VDD for amplifier
- ◆ 3.4W Output at 10% THD with a 4Ω Load and 5V VDD for amplifier
- ◆ 2.7W Output at 1% THD with a 4Ω Load and 5V VDD for amplifier
- ◆ Filterless, Low Quiescent Current and Low EMI
- ◆ Amplifier Efficiency up to 85%
- ◆ Free LC filter digital modulation, direct-drive speakers
- ◆ Short Circuit Protection
- ◆ Thermal Shutdown
- ◆ Few external components to save the space and cost
- ◆ Pb-Free Package

Applications

- ✧ Portable Bluetooth Speaker
- ✧ Cellular and Smart mobile phone
- ✧ Square Speaker

Marking Information

Device	Marking	Package	Shipping
LPA2173SPF	LPS LPA2173 YWX	ESOP-8	4K/REEL

Y: Y is year code. W: W is week code. X: X is series number.

Typical Application Circuit

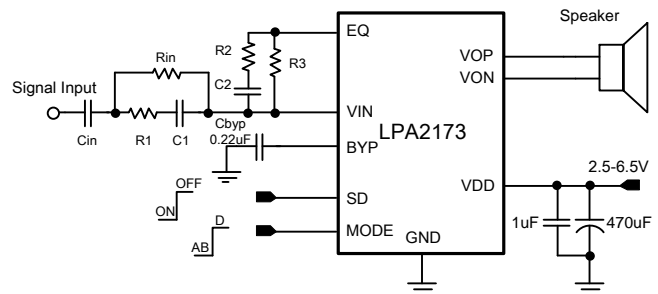



Pin Configuration

Package Type	Pin Configurations
ESOP-8	

Functional Pin Description

Pin	PIN No.	DESCRIPTION
BYP	1	Bypass pin (Connect a 0.22uF capacitor between this pin and GND).
MODE	2	Mode control pin (High voltage with Class_D mode and low voltage with Class_AB mode).
EQ	3	EQ function pin(With resistor R2 and capacitor C2 in series between VIN and EQ, the high frequencies could be attenuated).
VIN	4	Input of amplifier.(With resistor R1 and capacitor C1 in series between IN- and signal, the low frequencies could be attenuated).
VOP	5	Positive output of signal.
VDD	6	Voltage supply pin.
VON	7	Negative output of signal.
SD	8	Shutdown pin (active high).
GND	9(PAD)	Ground pin.

Absolute Maximum Ratings

Input Voltage to GND	-----	-0.3V to 7.5V
Other pin to GND	-----	-0.3V to 6.5V
Lead Temperature (Soldering, 10 sec.)	-----	260°C
Storage Temperature Range	-----	-65°C to 165°C
Operation Junction Temperature Range	-----	-40°C to 125°C
Operation Ambient Temperature Range	-----	-40°C to 85°C
Maximum Power Dissipation (PD,TA<40°C)	-----	2.6W
Thermal resistance (junction to ambient)	-----	50°C/W



Electrical Characteristics For Amplifier

(VDD = 5V, RL=4Ω , TA = 25° C, unless otherwise specified)

Parameter	Symbol	Test Conditions	Min	Typ		Max	Units	
				Class-D	Class-AB			
Supply power	VIN		2.5			6.5	V	
Output power	Po	THD+N=10%, f=1KHz,RL=4Ω	VDD=6.5V		5.7	5.7		W
			VDD=5.5V		4.2	4.2		
			VDD=5.0V		3.36	3.4		
			VDD=4.2V		2.33	2.4		
			VDD=3.6V		1.72	1.75		
		THD+N=1%, f=1KHz,RL=4Ω	VDD=6.5V		4.6	4.6		
			VDD=5.5V		3.4	3.42		
			VDD=5.0V		2.7	2.72		
			VDD=4.2V		1.91	1.91		
			VDD=3.6V		1.4	1.4		
		THD+N=10%, f=1KHz,RL=2Ω	VDD=6.0V		8	8		
			VDD=5.5V		6.8	6.75		
			VDD=5.0V		5.64	5.6		
			VDD=4.2V		3.3	3.9		
		THD+N=10%, f=1KHz,RL=8Ω	VDD=6.0V		2.2	2		
			VDD=5.5V		1.8	1.5		
			VDD=5.0V		1.5	1.4		
			VDD=4.2V		1.1	1.1		
			VDD=3.6V		0.8	0.8		
		THD+N=1%, f=1KHz,RL=8Ω	VDD=6.0V		1.8	1.7		
VDD=5.5V			1.5	1.3				
VDD=5.0V			1.25	1.25				
VDD=4.2V			0.9	0.88				
VDD=3.6V			0.65	0.64				
Power supply ripple rejection	PSRR	INPUT ac-grounded with CIN=0.47uF, VDD=6.0V	f=100HZ		75		dB	
			f=1KHz		50			
Signal-to-noise ratio	SNR	VDD=5V,Class_AB	f=1KHz		91		dB	
		VDD=5V,Class_D	f=1KHz		90			
Output noise	VN	INPUT ac-grounded with			100		μV	
Efficiency	η	RL=4Ω, Po=3.2W	f=1KHz		84		%	
VOS		VDD=5.0V, VSD =0V			1.1	2.5	mV	



Threshold voltage of class D	VMOD_D	VDD=2.5-6.5V		75%VDD			V
Threshold voltage of class AB	VMOD_A B	VDD=2.5-6.5V				50%VDD	V
Threshold voltage of shutdown pin	VSD_H	VDD=2.5-6.5V		1.4			V
	VSD_L	VDD=2.5-6.5V				0.4	V
Shutdown current	ILEAK	VSD =VDD=5.0V				2	uA
Quiescent current	IQ	VDD=5.0V	No load		4	6.8	mA

Typical Operating Characteristic Audio Precision

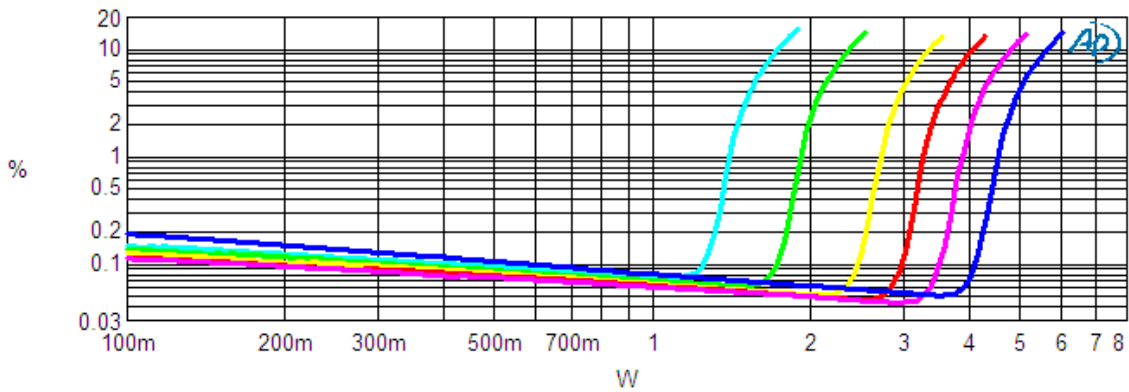

Sweep	Trace	Color	Line Style	Thick	Data	Axis	Comment
1	1	Cyan	Solid	3	Analyzer.THD+N Ratio A	Left	VDD=3.6V Class AB
2	1	Green	Solid	3	Analyzer.THD+N Ratio A	Left	VDD=4.2V Class AB
3	1	Yellow	Solid	3	Analyzer.THD+N Ratio A	Left	VDD=5.0V Class AB
4	1	Red	Solid	3	Analyzer.THD+N Ratio A	Left	VDD=5.5V Class AB
5	1	Magenta	Solid	3	Analyzer.THD+N Ratio A	Left	VDD=6.0V Class AB
6	1	Blue	Solid	3	Analyzer.THD+N Ratio A	Left	VDD=6.5V Class AB

PO VS THD(4ohm AB).ats2



Audio Precision

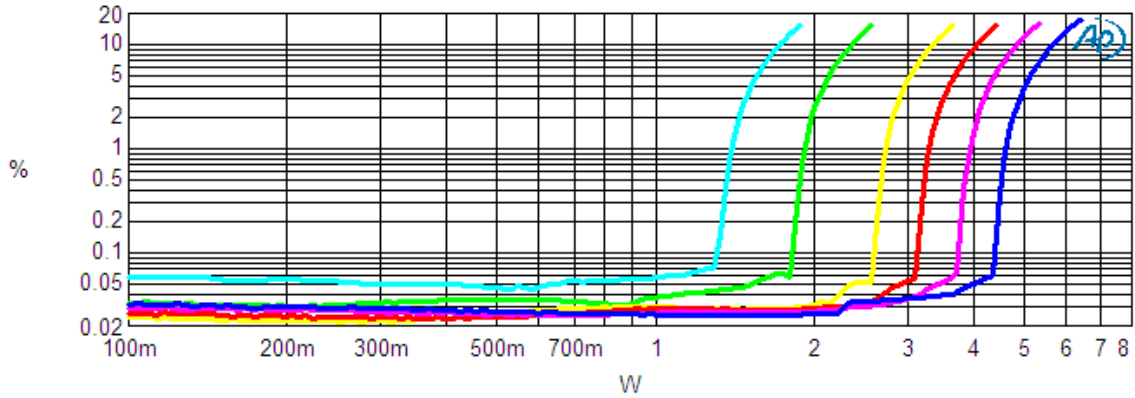

Sweep	Trace	Color	Line Style	Thick	Data	Axis	Comment
1	1	Cyan	Solid	3	Analyzer.TH+N Ratio A	Left	VDD=3.6V Class D
2	1	Green	Solid	3	Analyzer.TH+N Ratio A	Left	VDD=4.2V Class D
3	1	Yellow	Solid	3	Analyzer.TH+N Ratio A	Left	VDD=5.0V Class D
4	1	Red	Solid	3	Analyzer.TH+N Ratio A	Left	VDD=5.5V Class D
5	1	Magenta	Solid	3	Analyzer.TH+N Ratio A	Left	VDD=6.0V Class D
6	1	Blue	Solid	3	Analyzer.TH+N Ratio A	Left	VDD=6.5V Class D

P0 VS THD(4ohm D).ats2

Audio Precision

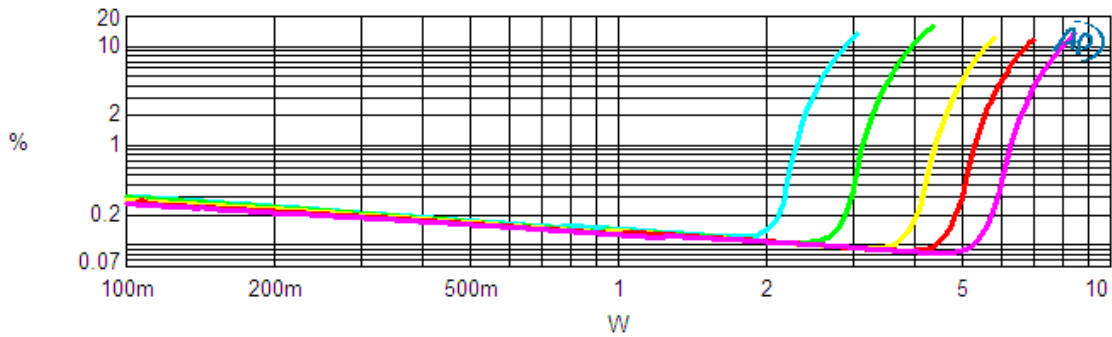

Sweep	Trace	Color	Line Style	Thick	Data	Axis	Comment
1	1	Cyan	Solid	3	Analyzer.TH+N Ratio A	Left	VDD=3.6V Class AB
2	1	Green	Solid	3	Analyzer.TH+N Ratio A	Left	VDD=4.2V Class AB
3	1	Yellow	Solid	3	Analyzer.TH+N Ratio A	Left	VDD=5.0V Class AB
4	1	Red	Solid	3	Analyzer.TH+N Ratio A	Left	VDD=5.5V Class AB
5	1	Magenta	Solid	3	Analyzer.TH+N Ratio A	Left	VDD=6.0V Class AB

P0 VS THD(2ohm AB).ats2



Audio Precision

A-A THD+N vs FREQUENCY

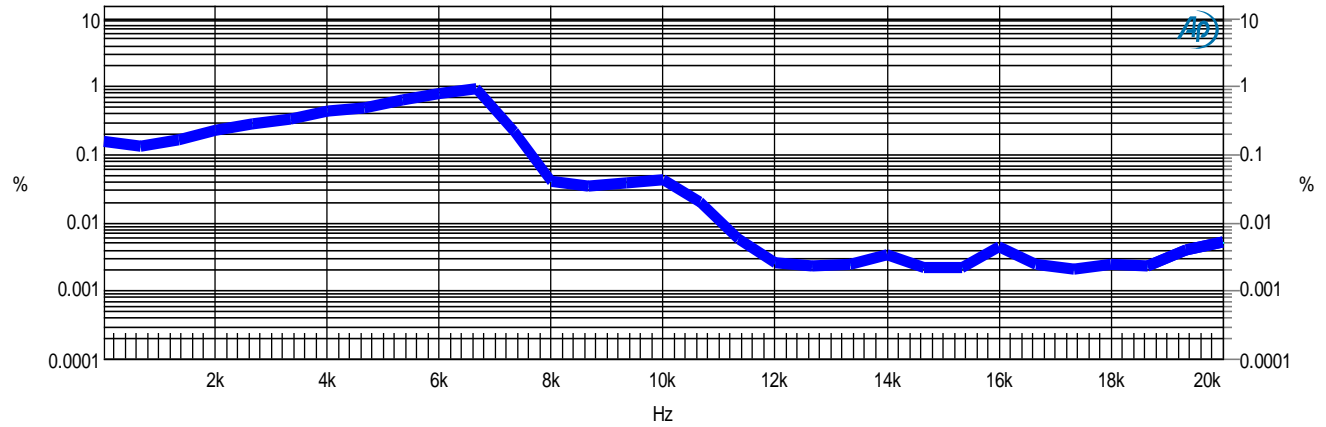

Sweep	Trace	Color	Line Style	Thick	Data	Axis	Comment
1	1	Cyan	Solid	1	Analyzer.TH+D+N Ratio B	Left	
1	2	Blue	Solid	7	Analyzer.TH+D+N Ratio B	Right	

A single sweeps produces a stereo THD+N sweep of Ch A and Ch B when data 1 is set for THD+N and the Stereo box is checked. The upper Analyzer bandwidth is 20kHz. At a 6kHz fundamental only the 2nd and 3rd harmonics are included, above 10kHz only the noise is included in the measurement bandwidth. For band-limited systems IMD testing is better.

A-A THD+N VS FREQ @4ohm PO=3W CLASS D VDD=6V.ats2



Audio Precision

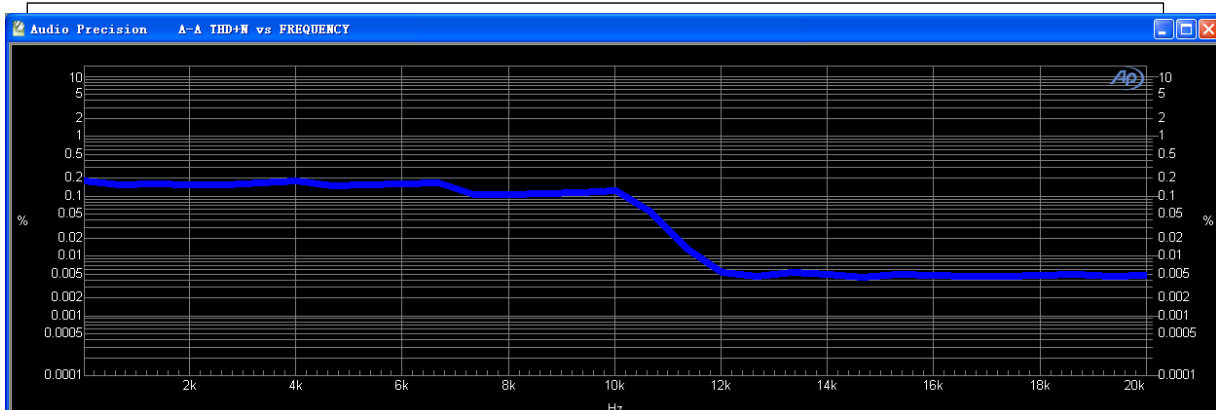
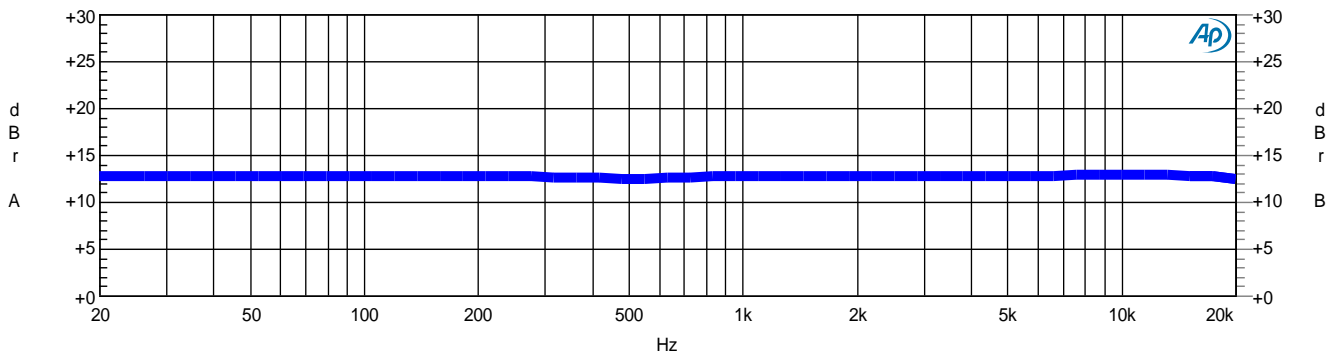



Applications Information

Maximum Gain

The LPA2173 has two internal amplifier stages. The first stage's gain is externally configurable, while the second stage's is internally fixed. The closed-loop gain of the first stage is set by selecting the ratio of R3 to Rin while the second stage's gain is fixed at 1.5x. The output of amplifier serves as the input to amplifier 2, thus the two amplifiers produce signals identical in magnitude, but different in phase by 180°. Consequently, the differential gain for the IC is:

$$A_v = 2 * 1.5 * R_3 / R_{in} \text{ (for class_AB \& class_D)}$$

Shutdown operation

In order to reduce power consumption while not in use, the LPA2173 contains shutdown circuitry to turn off the amplifier's bias circuitry. This shutdown feature turns the amplifier off when logic high is applied to the SD pin. By switching the SD pin connected to VDD, the LPA2173 supply current draw will be minimized in idle mode. The SD pin can be left floating due to the internal pull-up.

Power supply decoupling

The LPA2173 is a high performance CMOS audio amplifier that requires adequate power supply decoupling to ensure the output THD and PSRR a low as possible. Power supply decoupling affects low frequency response. Optimum decoupling is achieved by using two capacitors of different types targeting to different types of noise on the power supply leads. For higher frequency transients, spikes, or digital hash on the line, a good low equivalent-series-resistance(ESR) ceramic capacitor, typically 1.0µF, works best, placing it as close as possible to the device VDD terminal. For filtering lower-frequency noise signals, a large capacitor of 20µF(ceramic) or greater is recommended, placing it

near the audio power amplifier.

Short Circuit Protection (SCP)

The LPA2173 has short circuit protection circuitry on the outputs to prevent damage to the device when output-to-output or output-to-GND short occurs. When a short circuit is detected on the outputs, the outputs are disabled immediately. If the short was removed, the device activates again.

Signal Frequency suppress

The LPA2173 has a EQ pin which is the negative output of amplifier as show below. With R2 and C2, we can suppress high frequency part of signal. And the low frequency part of signal could be attenuated by R1 and C1.

$$f_H = \frac{1}{2\pi R_1 C_1} ; f_L = \frac{1}{2\pi R_2 C_2}$$

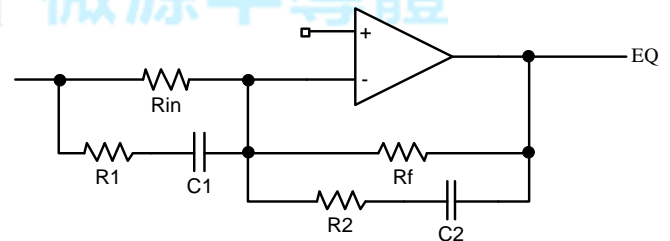

Over Temperature Protection

Thermal protection on the LPA2173 prevents the device from damage when the internal die temperature exceeds 150 °C . Once the die temperature exceeds the thermal set point, the device outputs are disabled. This is not a latched fault. The thermal fault is cleared once the temperature of the die is reduced by 30°C. This large hysteresis will prevent motor boating sound well and the device begins normal operation at this point without external system intervention.



Analog Reference Bypass Capacitor (C_{BYP})

In addition to system cost and size, click and pop performance is affected by the size of the input coupling capacitor, C_{BYP} . A larger input coupling capacitor requires more charge to reach its quiescent DC voltage (nominally $1/2 V_{DD}$). This charge comes from the internal circuit via the feedback and is apt to create pops upon device enable. Thus, by minimizing the capacitor size based on necessary low frequency response, turn-on pops can be minimized.

The Analog Reference Bypass Capacitor (C_{BYP}) is the most critical capacitor and serves several important functions. During start-up or recovery from shutdown mode, C_{BYP} determines the rate at which the amplifier starts up. The second function is to reduce noise caused by the power supply coupling into the output drive signal. This noise is from the internal analog reference to the amplifier, which

appears as degraded PSRR and THD+N.

How to reduce EMI

A simple solution is to put an additional capacitor 220pF at power supply terminal for power line. The traces from amplifier to speakers should design as short as we can.

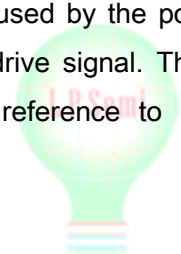
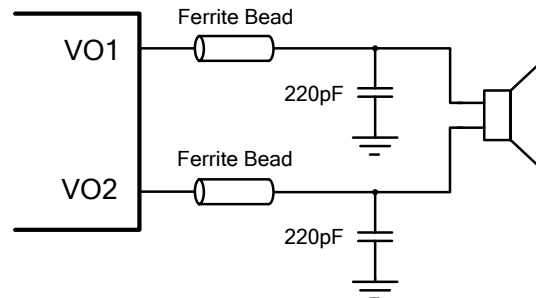



Packaging Information

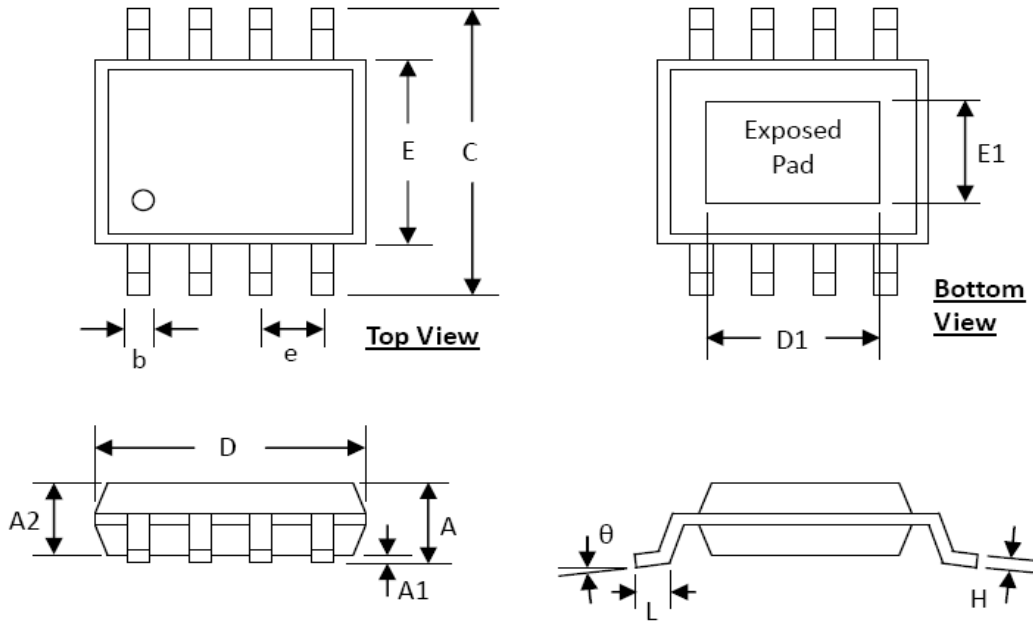

SYMBOLS	DIMENSION (MM)		DIMENSION (INCH)	
	MIN	MAX	MIN	MAX
A	1.30	1.70	0.051	0.067
A1	0.00	0.15	0.000	0.006
A2	1.25	1.52	0.049	0.060
b	0.33	0.51	0.013	0.020
C	5.80	6.20	0.228	0.244
D	4.80	5.00	0.189	0.197
D1	3.15	3.45	0.124	0.136
E	3.80	4.00	0.150	0.157
E1	2.26	2.56	0.089	0.101
e	1.27 BSC		0.050 BSC	
H	0.19	0.25	0.0075	0.0098
L	0.41	1.27	0.016	0.050
θ	0°	8°	0°	8°