



Filterless 3W Class- D Mono Audio Amplifier

General Description

The LPA4809 is a dual audio power amplifier capable of delivering 140mW per channel of continuous average power into a 16Ω load with 0.1 % (THD+N) from a 5V power supply. Boomer audio power amplifier was designed specifically to provide high quality output power with a minimal amount of external components. Since the LPA4809 does not require bootstrap capacitors or snubber networks, it is optimally suited for low-power portable systems. The unity-gain stable LPA4809 can be configured by external gain-setting resistors. The LPA4809 features an externally controlled, active-low, micro power consumption shutdown mode, as well as an internal thermal shutdown protection mechanism.

Features

- ◆ THD+N at 1KHz at 140mW continuous average power into 16Ω 0.1%
- ◆ THD+N at 1KHz at 80mW continuous average power into 32Ω 0.1%
- ◆ Shutdown Current 0.5uA
- ◆ Active-low shutdown mode
- ◆ “Click and Pop” reduction circuitry
- ◆ Low shutdown current
- ◆ MSOP8 surface mount packaging
- ◆ No bootstrap capacitors required
- ◆ Unity-gain stable

Order Information

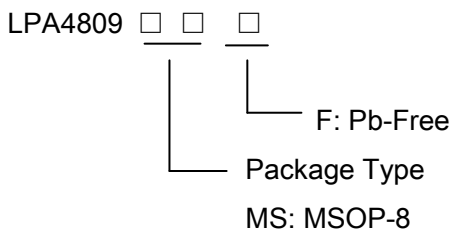

Marking Information

Device	Marking	Package	Shipping
LPA4809MSF	LPS LPA4809M YWX	MSOP-8	3K/REEL
Y: Y is year code. W: W is week code. X: X is series number.			

Applications Headphone Amplifier

- ✧ Microphone Preamplifier
- ✧ Personal Computers
- ✧ PDA`s

Typical Application Circuit

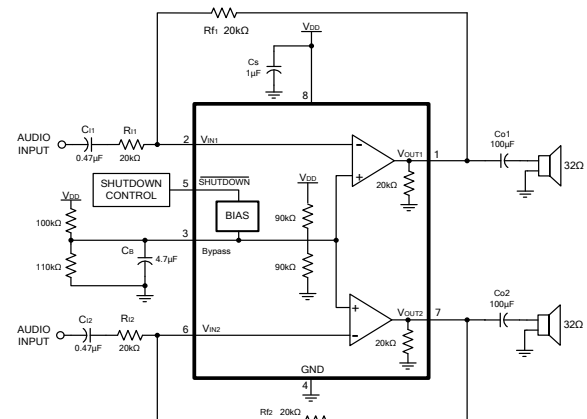



Functional Pin Description

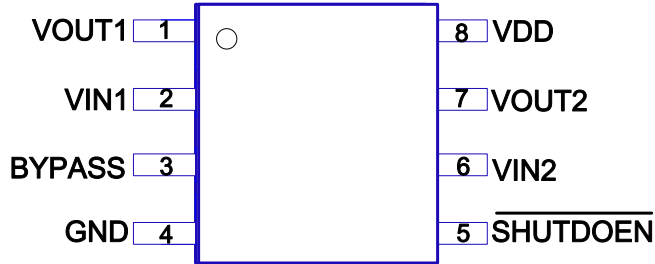

Functional Pin Description

Pin	PIN No.	DESCRIPTION
VOUT1	1	Output of channel 1.
VIN1	2	Signal input of channel 1.
BYPASS	3	Bypass capacitor pin which increase chip performance.
GND	4	Ground pin.
SHUTDOWN	5	The device enters in shutdown mode when a low voltage is applied on this pin.
VIN2	6	Signal input of channel 2.
VOUT2	7	Output of channel 2.
VDD	8	Supply voltage pin.



Absolute Maximum Ratings ^{Note 1}

- ◇ VDD Voltage to GND ----- -0.3V to 6.0V
- ◇ SVoltage at Any Input Pin ----- -0.3 V to VDD +0.3
- ◇ Junction Temperature, TJMAX ----- 150°C
- ◇ Storage Temperature Rang, Tstg ----- -65°C to 150°C
- ◇ Maximum Soldering Temperature (at leads, 10 sec) ----- 260°C

Note 1. Stresses beyond those listed under “Absolute Maximum Ratings” may cause permanent damage to the device. These are stress ratings only, and functional operation of the device at these or any other conditions beyond those indicated in the operational sections of the specifications is not implied. Exposure to absolute maximum rating conditions for extended periods may affect device reliability.

Thermal Information

- ◇ Maximum Power Dissipation (PD,TA=25°C) ----- 1.0W
- ◇ Thermal Resistance (JA) ----- 120°C/W

ESD Susceptibility

- ◇ HBM(Human Body Mode) ^{Note 2} ----- 2KV
- ◇ MM(Machine Mode) ^{Note 3} ----- 200V

Note 2. The Human body model (HBM) is a 100pF capacitor discharged through a 1.5kΩ resistor into each pin. The testing is done according JEDEC.

Note 3. Machine Model (MM) is a 200pF capacitor discharged through a 500nH inductor with no series resistor into each pin. The testing is done according JEDEC.

Electrical Characteristics For Amplifier

(VDD = 5V, TA = 25° C, unless otherwise specified)

Parameter	Symbol	Test Conditions	Min	Typ	Max	Units
Supply power	V _{DD}		2.0		5.5	V
Supply Current	I _{DD}				5	mA
Shutdown Current	I _{SD}			0.5	5	uA
Output offset voltage	V _{OS}			4	50	mV
Output power	P _o	THD+N=0.1%, f=1KHz, RL=16Ω		140		mW
		THD+N=0.1%, f=1KHz, RL=32Ω	70	80		
Total harmonic distortion	THD+N	Po=50mW, RL=32 Ω , f=20Hz to 20KHz		0.3		%
Channel Separation	Crosstalk	RL=32 Ω ; Po=70mW		70		dB
Power supply rejection ratio	PSRR	CB=1uF; VRIPPLE=200mV; f=1kHz; Input terminated into 50 Ω		70		dB
High-level input voltage	V _{SD_H}	VDD=5.0V	1.4			V
Low-level input voltage	V _{SD_L}	VDD=5.0V			0.4	V



(VDD = 3.3V, TA = 25° C, unless otherwise specified)

Parameter	Symbol	Test Conditions	Min	Typ	Max	Units
Supply Current	I _{DD}				2.2	mA
Shutdown Current	I _{SD}				1.8	uA
Output offset voltage	V _{OS}			4		mV
Output power	P _o	THD+N=0.1%, f=1KHz, RL=16Ω		60		mW
		THD+N=0.1%, f=1KHz, RL=32Ω		30		
Total harmonic distortion	THD+N	P _o =50mW, RL=32 Ω , f=20Hz to 20KHz		0.4		%
Channel Separation	Crosstalk	RL=32 Ω ; P _o =70mW		70		dB
Power supply rejection ratio	PSRR	CB=1uF; VRIPPLE=200mV; f=1kHz; Input terminated into 50 Ω		70		dB
High-level input voltage	V _{SD_H}	VDD=5.0V	1.4			V
Low-level input voltage	V _{SD_L}	VDD=5.0V			0.4	V

(VDD = 2.6V, TA = 25° C, unless otherwise specified)

Parameter	Symbol	Test Conditions	Min	Typ	Max	Units
Supply Current	I _{DD}			0.9		mA
Shutdown Current	I _{SD}			0.2		uA
Output offset voltage	V _{OS}			4		mV
Output power	P _o	THD+N=0.1%, f=1KHz, RL=16Ω		20		mW
		THD+N=0.1%, f=1KHz, RL=32Ω		16		
Total harmonic distortion	THD+N	P _o =50mW, RL=32 Ω , f=20Hz to 20KHz		0.6		%
Channel Separation	Crosstalk	RL=32 Ω ; P _o =70mW		70		dB
Power supply rejection ratio	PSRR	CB=1uF; VRIPPLE=200mV; f=1kHz; Input terminated into 50 Ω		70		dB
High-level input voltage	V _{SD_H}	VDD=5.0V	1.4			V
Low-level input voltage	V _{SD_L}	VDD=5.0V			0.4	V



Typical Operating Characteristic

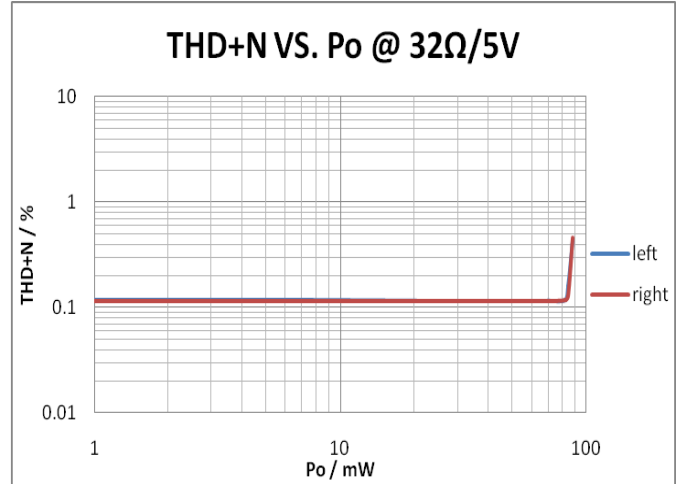
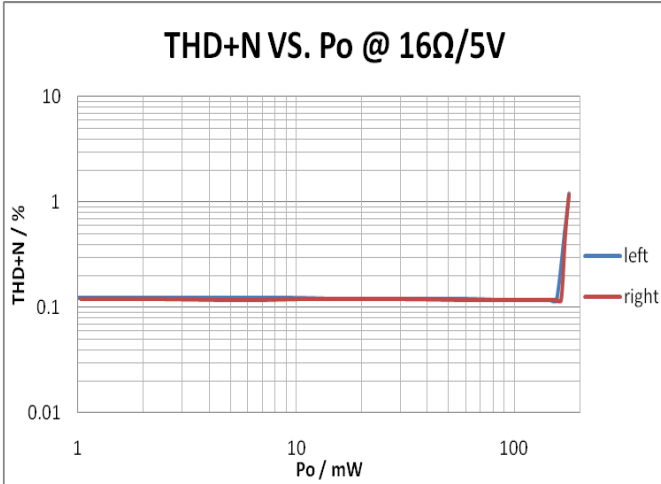

Frequency VS THD

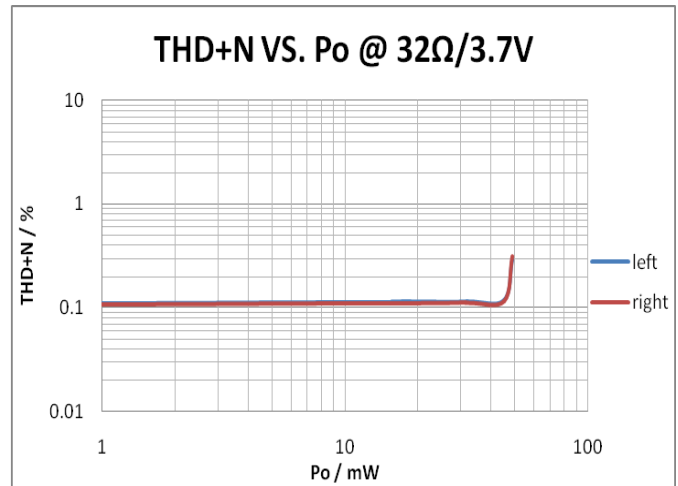
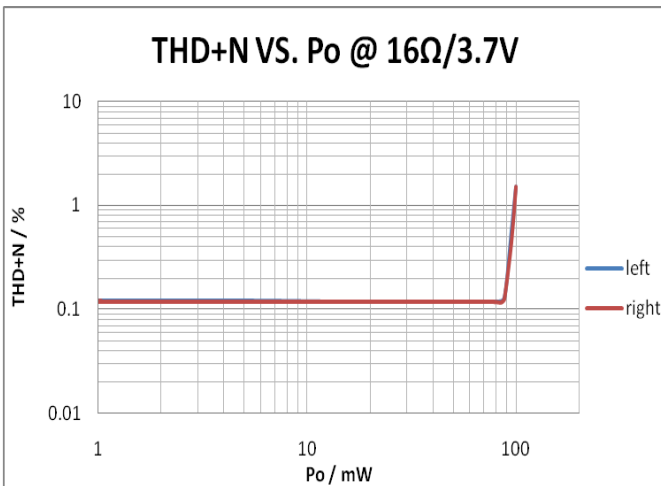
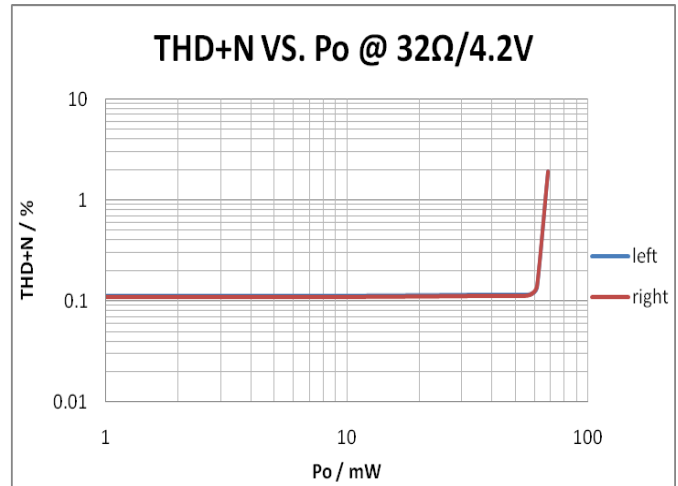
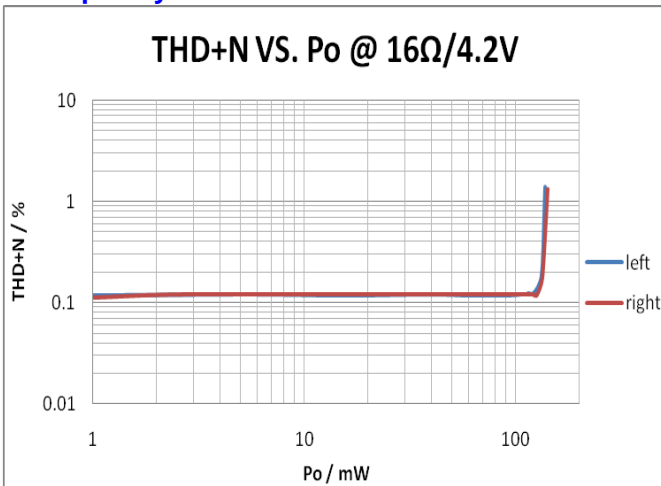

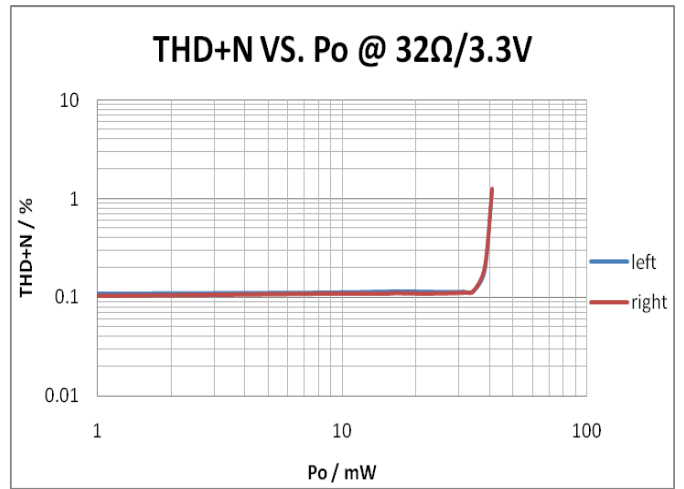
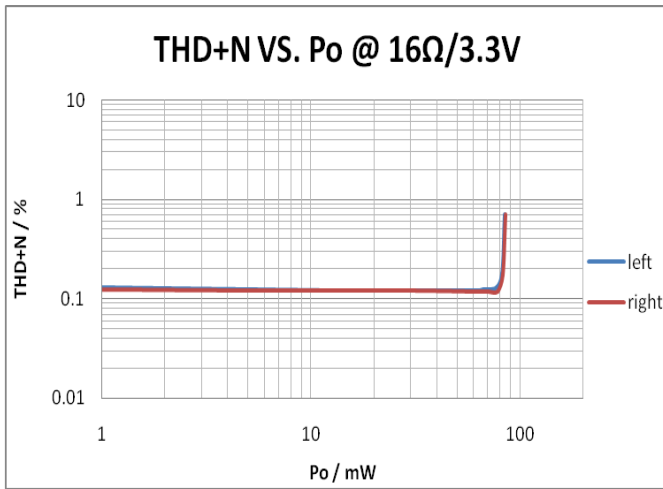

Av VS. Frequency @ $R_L=16\Omega$

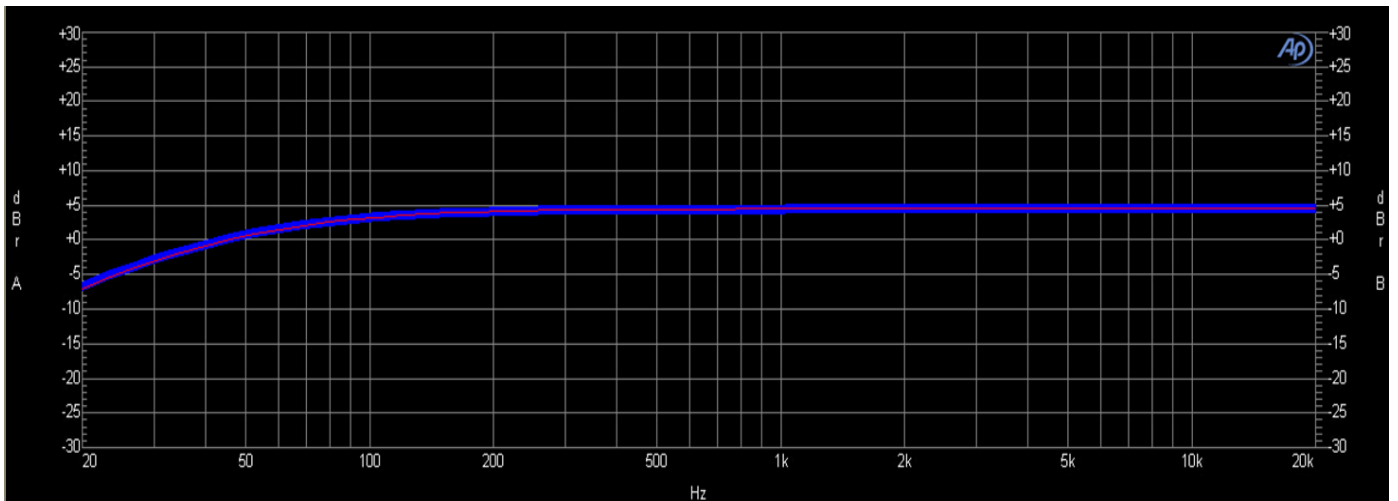

Av VS. Frequency @ $R_L=32\Omega$

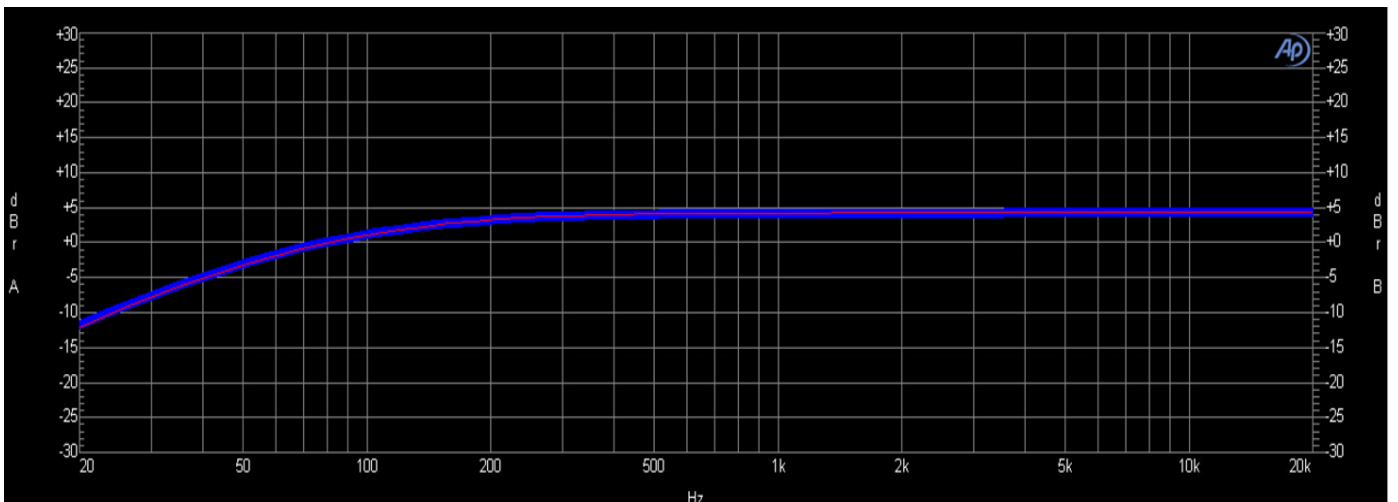



Applications Information

Shutdown the Amplifier

By applying a logic low voltage to the SHUTDOWN pin, we can shutdown the chip. When active, the LPA4809's shutdown feature turns off the amplifier's bias circuitry, reducing the supply current. The low 0.5µA typical shutdown current is achieved by applying a voltage that is as near as GND as possible to the SHUTDOWN pin. There are a few ways to control the chip's shutdown. These include using a single-pole, single-throw switch, a microprocessor, or a microcontroller. When using a switch, connect an external 100k pull down resistor between the SHUTDOWN pin and GND. Connect the switch between the SHUTDOWN pin and VDD. Select normal amplifier operation by closing the switch. Opening the switch connects the SHUTDOWN pin to GND through the pull-down resistor, activating chip shutdown. The switch and resistor guarantee that the SHUTDOWN pin will not float. This prevents unwanted state changes. In a system with a microprocessor or a microcontroller, use a digital output to apply the control voltage to the SHUTDOWN pin. Driving the SHUTDOWN pin with active circuitry eliminates the pull-down resistor.

Power Dissipation

Power dissipation is a major concern when using any power amplifier and must be thoroughly understood to ensure a successful design. Equation 1 states the maximum power dissipation point for a single-ended amplifier operating at a given supply voltage and driving a specified output load.

$$P_{D_{MAX}} = (V_{DD})^2 / (2\pi^2 R_L) \text{ -----①}$$

Since the LPA4809 has two operational amplifiers in one package, the maximum internal power dissipation point is twice that of the number which results from Equation 1. Even with the large internal power dissipation, the LPA4809 does not require sinking over a large range of ambient temperature. From Equation 1, assuming a 5V power supply and a 32Ω load, the maximum power dissipation point is 40mW per amplifier. Thus the maximum package dissipation point is 80mW. The maximum power dissipation point obtained must not be greater than the power dissipation that results from Equation 2:

$$P_{D_{MAX}} = (T_{J_{MAX}} - T_A) / \theta_{JA} \text{ -----②}$$

For package MSOP8, $\theta_{JA} = 120^\circ\text{C/W}$. $T_{J_{MAX}} = 150^\circ\text{C}$ for the LPA4809. Depending on the ambient temperature, T_A of the system surroundings, Equation 2 can be used to find the maximum internal power dissipation supported by the IC packaging. If the result of Equation 1 is greater than that of Equation 2, then either the supply voltage must be decreased, the load impedance increased or T_A reduced. For the typical application of a 5V power supply with a 32 load, the maximum ambient temperature possible without violating the maximum junction temperature is approximately 133.2°C provided that device operation is around the maximum power dissipation point. Power dissipation is a function of output power and thus, if typical operation is not around the maximum power dissipation point, the ambient temperature may be increased accordingly.



Power Supply Bypassing

As with any power amplifier, proper supply bypassing is critical for low noise performance and high power supply rejection. Applications that employ a 5V regulator typically use a 10µF in parallel with a 0.1µF filter capacitors to stabilize the regulator’s output, reduce noise on the supply line, and improve the supply’s transient response. However, their presence does not eliminate the need for a local 1.0µF tantalum bypass capacitance connected between the LPA4809’s supply pins and ground. Keep the length of leads and traces that connect capacitors between the LPA4809’s power supply pin and ground as short as possible. Connecting a 4.7µF capacitor, CB, between the BYPASS pin and ground improves the internal bias voltage’s stability and improves the amplifier’s PSRR. The PSRR improvements increase as the bypass pin capacitor value increases. A large value, however, increases the amplifier’s turn-on time. The selection of bypass capacitor values, especially CB, depends on desired PSRR requirements, click and pop performance (as explained in the section, Selecting Proper External Components), system cost, and size constraints.

Selecting Proper External Components

Optimizing the LPA4809’s performance requires properly selecting external components. Though the LPA4809 operates well when using external components with wide tolerances, best performance is achieved by optimizing component values.

The LPA4809 is unity-gain stable, giving a designer maximum design flexibility. The gain should be set to no more than a given application requires. This allows the amplifier to achieve minimum THD+N and maximum signal-to-noise ratio. These parameters are compromised as the closed-loop gain increases.

However, low gain demands input signals with greater voltage swings to achieve maximum output power.

Input and Output Capacitor Value Selection

Amplifying the lowest audio frequencies requires high value input and output coupling capacitors (CI and CO in Figure 1). A high value capacitor can be expensive and may compromise space efficiency in portable designs. In many cases, however, the speakers used in portable systems, whether internal or external, have little ability to reproduce signals below 150Hz. Applications using speakers with this limited frequency response reap little improvement by using high value input and output capacitors.

Besides affecting system cost and size, Ci has an effect on the LPA4809’s click and pop performance. The magnitude of the pop is directly proportional to the input capacitor’s size. Thus, pops can be minimized by selecting an input capacitor value that is no higher than necessary to meet the desired .3dB frequency. Please refer to the Optimizing Click and Pop Reduction Performance section for a more detailed discussion on click and pop performance.

The input resistor, RI and the input capacitor, CI, produce a 3dB high pass filter cutoff frequency that is found using Equation (3). In addition, the output load RL, and the output capacitor CO, produce a -3dB high pass filter cutoff frequency defined by Equation (4).

$$f_{l-3db} = 1/2\pi R_I C_I \text{ ----- } \textcircled{3}$$

$$f_{O-3db} = 1/2\pi R_L C_O \text{ ----- } \textcircled{4}$$

Also, careful consideration must be taken in selecting a certain type of capacitor to be used in the system. Different types of capacitors (tantalum, electrolytic, ceramic) have unique performance characteristics and may affect overall system performance.



Bypass Capacitor Value Selection

Besides minimizing the input capacitor size, careful consideration should be paid to the value of C_B , the capacitor connected to the BYPASS pin. Since C_B determines how fast the LPA4809 settles to quiescent operation, its value is critical when minimizing turn-on pops. The slower the LPA4809's outputs ramp to their quiescent DC voltage (nominally $1/2 V_{DD}$), the smaller the turn-on pop. Choosing C_B equal to $4.7\mu F$ along with a small value of C_i (in the range of $0.1\mu F$ to $0.47\mu F$), produces a click-less and pop-less shutdown function. As discussed above, choosing C_i no larger than necessary for the desired band with helps minimize clicks and pops.

Optimizing Click and POP Reduction Performance

The LPA4809 contains circuitry that minimizes turn-on and shutdown transients or "clicks and pop". For this discussion, turn-on refers to either applying the power supply voltage or when the shutdown mode is deactivated. During turn-on, the LPA4809's internal amplifiers are configured as unity gain buffers. An internal current source charges up the capacitor on the BYPASS pin in a controlled, linear manner. The gain of the internal amplifiers remains unity until the voltage on the BYPASS pin reaches $1/2 V_{DD}$. As soon as the voltage on the BYPASS pin is stable, the device becomes fully operational. During device turn-on, a transient (pop) is created from a voltage difference between the input and output of the amplifier as the voltage on the BYPASS pin reaches $1/2 V_{DD}$. For this discussion, the input of the amplifier refers to the node between R_I and C_I . Ideally, the input and output track the voltage applied to the BYPASS pin. During turn-on, the

buffer-configured amplifier output charges the input capacitor, C_I , through the input resistor, R_I . This input resistor delays the charging time of C_I thereby causing the voltage difference between the input and output that results in a transient (pop). Higher value capacitors need more time to reach a quiescent DC voltage (usually $1/2 V_{DD}$) when charged with a fixed current. Decreasing the value of C_I and R_I will minimize turn-on pops at the expense of the desired -3dB frequency.

Although the BYPASS pin current cannot be modified, changing the size of C_B alters the device's turn-on time and the magnitude of "clicks and pops". Increasing the value of C_B reduces the magnitude of turn-on pops. However, this presents a tradeoff: as the size of C_B increases, the turn-on time increases. In order eliminate "clicks and pops", all capacitors must be discharged before turn-on. Rapidly switching V_{DD} may not allow the capacitors to fully discharge, which may cause "clicks and pops". In a single-ended configuration, the output is coupled to the load by C_O . This capacitor usually has a high value. C_O discharges through internal 20k resistors. Depending on the size of C_O , the discharge time constant can be relatively large. To reduce transients in single-ended mode, an external $1k\Omega$ – $5k$ resistor can be placed in parallel with the internal 20k resistor. The tradeoff for using this resistor is increased quiescent current.

Audio Power Amplifier Design

Design a Dual 70mW/32. Audio Amplifier

Given:

Power Output: 70 mW

Load Impedance: 32

Input Level: 1 Vrms (max)

Input Impedance: 20k



Bandwidth: 100 Hz–20 kHz ± 0.50dB

The design begins by specifying the minimum supply voltage necessary to obtain the specified output power. One way to find the minimum supply voltage is to use the Output Power vs Supply Voltage curve in the Typical Performance Characteristics section. Another way, using Equation (5), is to calculate the peak output voltage necessary to achieve the desired output power for a given load impedance. To account for the amplifier’s dropout voltage, two additional voltages, based on the Dropout Voltage vs Supply Voltage in the Typical Performance Characteristics curves, must be added to the result obtained by Equation (5). For a single-ended application, the result is Equation (6).

$$V_{\text{peak}} = (2RLPO)0.5 \text{-----} \textcircled{5}$$

$$V_{\text{DD}} \geq (2V_{\text{OPEAK}} + (V_{\text{ODTOP}} + V_{\text{ODBOT}})) \text{-----} \textcircled{6}$$

The Output Power vs Supply Voltage graph for a 32 Ω load indicates a minimum supply voltage of 4.8V. This is easily met by the commonly used 5V supply voltage. The additional voltage creates the benefit of headroom, allowing the LPA4809 to produce peak output power in excess of 70mW without clipping or other audible distortion. The choice of supply voltage must also not create a situation that violates maximum power dissipation as explained above in the Power Dissipation section. Remember that the maximum power dissipation point from Equation (1) must be multiplied by two since there are two independent amplifiers inside the package. Once the power dissipation equations have been addressed, the required gain can be determined from Equation

$$AV \geq (PORL) 0.5 / V_{\text{IN}} = V_{\text{ORMS}} / V_{\text{IRMS}} \text{-----} \textcircled{7}$$

Thus, a minimum gain of 1.497 allows the LPA4809 to reach full output swing and maintain low noise and THD+N performance. For this example, let AV=1.5.

The amplifiers overall gain is set using the input (Ri) and feedback (Rf) resistors. With the desired input impedance set at 20kΩ, the feedback resistor is found using Equation (8).

$$AV = R_f / R_i \text{-----} \textcircled{8}$$

The value of Rf is 30kΩ.

The last step in this design is setting the amplifier’s 3db frequency bandwidth. To achieve the desired ±0.25dB pass band magnitude variation limit, the low frequency response must extend to at least one fifth the lower bandwidth limit and the high frequency response must extend to at least five times the upper bandwidth limit. The gain variation for both response limits is 0.17dB, well within the ±0.25dB desired limit.

The results are

$$f_L = 100\text{Hz} / 5 = 20\text{Hz} \text{-----} \textcircled{9}$$

$$f_H = 20\text{kHz} * 5 = 100\text{kHz} \text{-----} \textcircled{10}$$

As stated in the External Components section, both Ri in conjunction with Ci, and Co with RL, create first order high-pass filters. Thus to obtain the desired low frequency response of 100Hz within ±0.5dB, both poles must be taken into consideration. The combination of two single order filters at the same frequency forms a second order response. This results in a signal which is down 0.34dB at five times away from the single order filter .3dB point. Thus, a frequency of 20Hz is used in the following equations to ensure that the response is better than 0.5dB down at 100Hz.



$$C_i \geq 1 / (2\pi * 20k * 20Hz) = 0.397\mu F ; \text{ use } 0.39\mu F \text{-----} \textcircled{11}$$

$$C_o \geq 1 / (2\pi * 32 * 20Hz) = 249\mu F ; \text{ use } 330\mu F \text{-----} \textcircled{12}$$

The high frequency pole is determined by the product of the desired high frequency pole, fH, and the closed-loop gain, AV. With a closed-loop gain of 1.5 and fH = 100kHz, the resulting GBWP = 150kHz which is much smaller than the LPA4809's GBWP of 900kHz. This figure displays that if a designer has a need to design an amplifier with a higher gain, the LPA4809 can still be used without running into bandwidth limitations.



Packaging Information

MSOP8

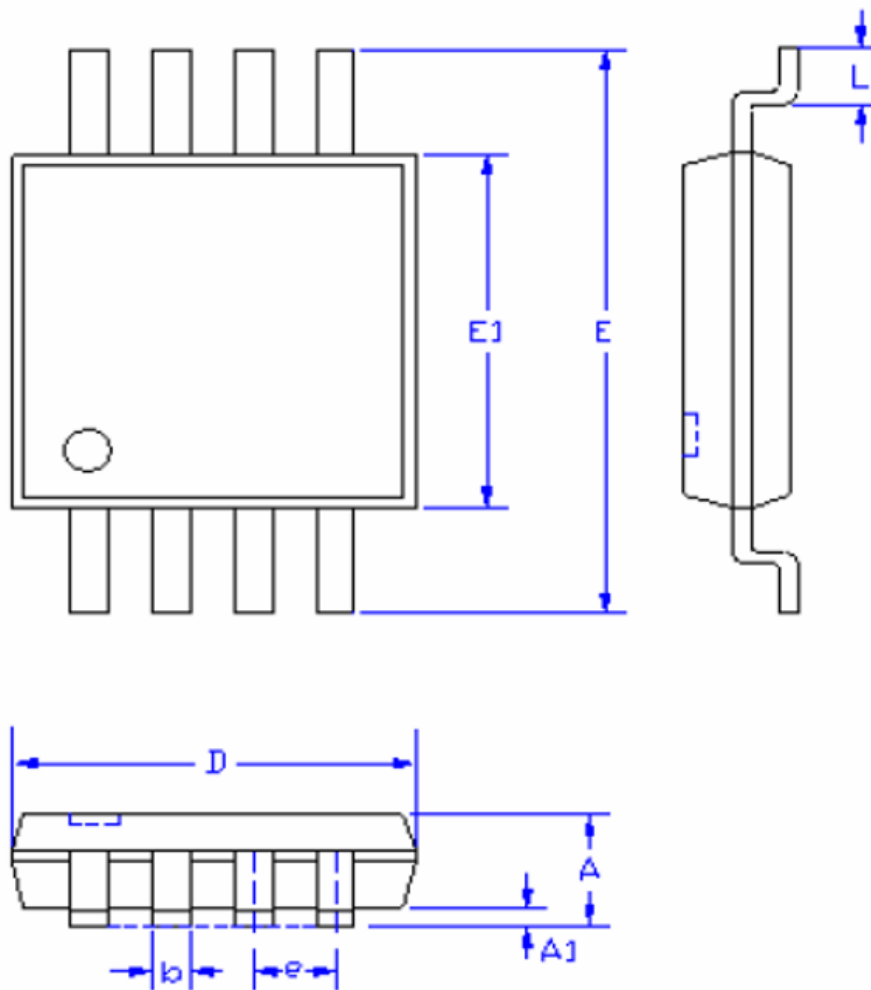

SYMBOLS	MILLIMETERS		INCHES	
	MIN.	MAX.	MIN.	MAX.
A	-	1.10	-	0.043
A1	0.00	0.15	0.000	0.006
D	3.00		0.118	
E1	3.00		0.118	
E	4.70	5.10	0.185	0.201
L	0.40	0.80	0.016	0.031
b	0.22	0.38	0.008	0.015
e	0.65		0.026	