



1A Single Chip Li-Ion and Li-Polymer Charger

General Description

The LP28013 is a complete constant-current/ constant voltage linear charger for single cell lithium-ion battery. Its TDFN-10 package and low external component count make the LP28013 ideally suited for portable applications. No external sense resistor is needed, and no blocking diode is required due to the internal MOSFET architecture. Thermal feedback regulates the charge current to limit the die temperature during high power operation or high ambient temperature. The charge voltage is fixed at 4.2V, and the charge current can be ISET programmed externally with a single resistor.

The LP28013 automatically terminates the charge cycle when the charge current drops to 1/10 setting current value after the final float voltage is reached.

When the input supply is removed, the LP28013 automatically enters a low current state, dropping the battery drain current to less than < 1µA.

Other features include charge current monitor, under voltage lockout, automatic recharge and a status pin to indicate charge termination and the presence of an input voltage.

Order Information

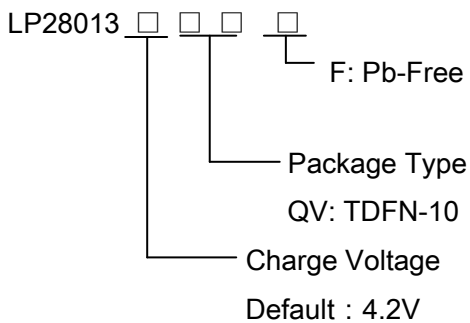

Applications

- ✧ Portable Media Players/Game
- ✧ Power Bank
- ✧ Bluetooth Applications
- ✧ PDA/MID

Features

- ◆ input voltage up to 28V
- ◆ input Over Voltage Protection : 7V
- ◆ Short-circuit protection
- ◆ Programmable Charge Current Up to 1000mA
- ◆ < 1µA Battery Reverse Current
- ◆ Protection of Reverse Connection of Battery
- ◆ No MOSFET, Sense Resistor or Blocking Diode Required
- ◆ Constant-Current/Constant-Voltage Operation with Thermal Regulation to Maximize Charge Rate Without Risk of Overheating
- ◆ TDFN-10 Package
- ◆ RoHS Compliant and 100% Lead (Pb)-Free

Typical Application Circuit

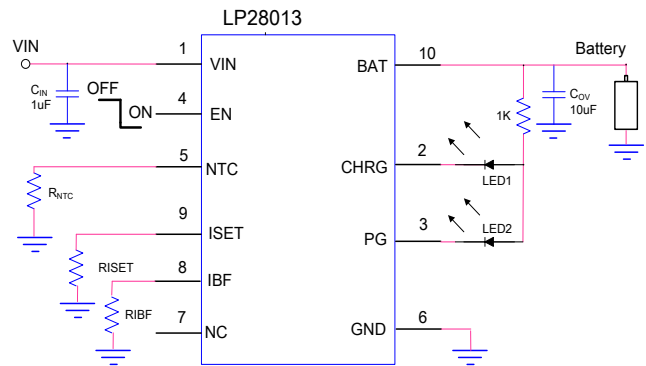

Marking Information

Device	Marking	Package	Shipping
LP28013	LPS LP28013 YWX	TDFN-10	3K/REEL

Marking indication:
Y:Production year W:Production week X: Series Number



Functional Pin Description

Package Type	Pin Configurations
TDFN-10	<p style="text-align: center;">TDFN-10 TOP VIEW</p>

Pin Description

PIN No.	PIN NAME	DESCRIPTION
1	VIN	VIN is the input power source. Connect to a wall adapter.
2	CHRG	Open-Drain Charge Status Output. When the battery is charging, the CHRG pin is pulled low by an internal NMOS. When the charge cycle is completed, the pin could be pulled High by an external pull high resistor.
3	PG	Open-Drain Status Output. Low indicates the input voltage is above UVLO and the OUT (battery) voltage.
4	EN	Charge Enable Input (active low).
5	NTC	Negative Thermal Coefficient (NTC) Thermistor Pin.
6	GND	GND is the connection to system ground.
7	NC	No Connector.
8	IBF	Charge Status Threshold Program. Connect this pin to an external resistor to program the charge termination current.
9	ISET	Charge Current Program. The charge current is programmed by connecting a 1% resistor(R_{ISET}) to ground.
10	BAT	BAT is the connection to the battery. Typically a 10 μ F Tantalum capacitor is needed for stability when there is no battery attached. When a battery is attached, only a 1 μ F ceramic capacitor is required.



Function Block Diagram

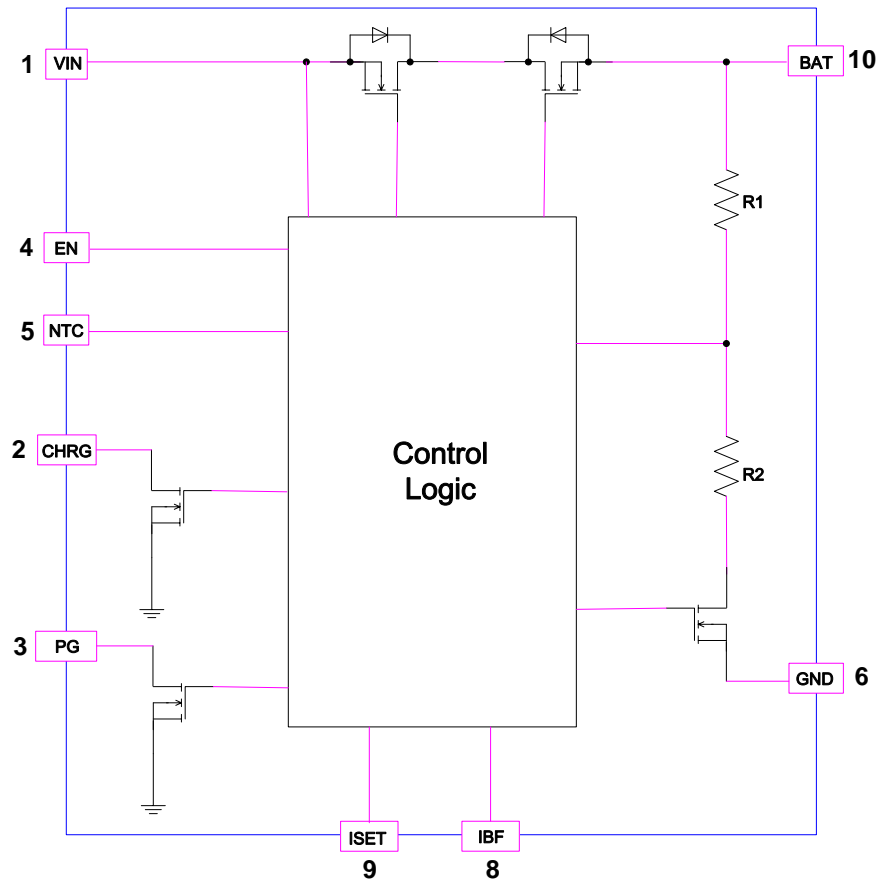

Absolute Maximum Ratings

- ✧ Input Voltage to GND ----- -0.3V to 28V
- ✧ BAT voltage GND ----- - 5V to 7V
- ✧ Other pin to GND ----- -0.3V to 6.5V
- ✧ Maximum Junction Temperature ----- 125°C
- ✧ Maximum Soldering Temperature (at leads, 10 sec) ----- 260°C
- ✧ Storage Temperature ----- -55°C to 150°C

Thermal Information

- ✧ Maximum Power Dissipation (PD,TA=25°C) ----- 1.5W
- ✧ Thermal Resistance (θ_{JA}) ----- 65°C/W

ESD Susceptibility

- ✧ HBM(Human Body Mode) ----- 2KV
- ✧ MM(Machine Mode) ----- 200V

Recommended Operating Conditions

- ✧ Input supply voltage ----- 3.5V to 6V
- ✧ Operating Ambient Temperature Range ----- -40°C to 85°C



Electrical Characteristics

($T_A = 25^\circ\text{C}$, $V_{IN} = 5\text{V}$, unless otherwise noted.)

SYMBOL	PARAMETER	CONDITIONS	MIN	TYP.	MAX	UNITS
V_{IN}	Input Voltage		3.5	5	28	V
I_{IN}	Input Supply Current	$I_{BAT} = 0$		1000		μA
V_{EN_L}	EN Logic-Low Voltage Threshold				0.4	V
V_{EN_H}	EN Logic-High Voltage Threshold		1.4			V
V_{FLOAT}	Regulated Output (Float) Voltage	$I_{BAT} = 40\text{mA}$,	4.158	4.2	4.242	V
V_{UV}	V_{IN} Under voltage Lockout Threshold	From V_{IN} Low to High	3.1	3.3	3.5	V
V_{UVHYS}	V_{IN} Under voltage Lockout Hysteresis			150		mV
V_{OVP}	Input Voltage OVP	V_{IN} Rising	6.7	7	7.3	V
$V_{OVP-HYS}$	OVP Hysteresis			0.2		V
I_{BAT}	BAT Pin Current	$R_{ISET} = 1.5\text{k}$, Current Mode		1000		mA
		$V_{BAT} = 4.2\text{V}$		1		μA
		$V_{in} = \text{float or } 0\text{V}$		1		μA
I_{TRIKL}	Trickle Charge Current	$V_{BAT} < V_{TRIKL}$, $R_{ISET} = 1.5\text{k}$, Current Mode		10		$\%I_{BAT}$
V_{TRIKL}	Trickle Charge Threshold Voltage	V_{BAT} Rising		2.6		V
V_{TRHYS}	Trickle Charge Hysteresis Voltage			150		mV
V_{ASD}	$V_{IN} - V_{BAT}$ Lockout Threshold Voltage	$V_{UV} < V_{IN}$		100		mV
I_{TERM}	Termination Current Threshold			10		$\%I_{BAT}$
V_{ISET}	ISET Pin Voltage	$R_{ISET} = 10\text{k}$, Current Mode		1		V
I_{STAT}	CHRG/PG Pin Weak Pull-Down Current	$V_{STAT} = 5\text{V}$			5	μA
V_{STAT}	CHRG Pin Output Low Voltage	$I_{STAT} = 5\text{mA}$			0.1	V
$V_{NTC-0^\circ\text{C}}$	Low temperature pending voltage threshold			1.18		V
$V_{NTC-10^\circ\text{C}}$	half charging current mode voltage threshold (Low temperature)			0.75		V
$V_{NTC-60^\circ\text{C}}$	High temperature Disable voltage threshold			0.17		V
V_{NTC_HYS}	Hysteresis			40		mV
I_{NTC}	NTC bias current	$R_{NTC} = 10\text{K}$		48		μA
V_{RESTAT}	Recharge Voltage Threshold	$V_{IN} = 5\text{V}$		4.05		V
ΔV_{RESTAT}	Recharge Battery Threshold Voltage	$V_{FLOAT} - V_{RESTAT}$		150		mV
T_{LIM}	Junction Temperature in Thermal Protection			125		$^\circ\text{C}$



Application Information

Input Voltage Range

The LP28013 has built-in input voltage surge protection as high as +28V. The charger IC will be automatically disabled when the input voltage is lower than 3.3V or higher than 7.0V. The open-drain PG Pin is used to indicate an input power good condition (3.3V<VIN<7.0V). If the input voltage is lower than the battery voltage, the IC is also disabled to prevent the battery from draining.

A charge cycle begins when the voltage at the VIN pin rises above the UVLO threshold level, when a battery is connected to the charger output. If the BAT pin is less than 2.6V, the charger enters trickle charge mode. In this mode, the LP28013 supplies approximately 1/10 the ISET programmed charge current to bring the battery voltage up to a safe level for full current charging. When the BAT pin voltage rises above 2.6V, the charger enters constant-current mode(CC), where the ISET programmed charge current is supplied to the battery. When the BAT pin approaches the final float voltage, the LP28013 enters constant-voltage mode(CV) and the charge current begins to decrease, and the battery full indication is set when the charge current in the CV mode is reduced to the programmed full battery current (IBF).

ISET programming Charge Current

The charge current (IBAT) is set by a resistor (RISET) connecting from the ISET pin to GND. The relationship of the charge current and the programming resistance is established by the following table.

RISET(KΩ)	IBAT(mA)
1.3	1150
1.5	1000
2	700
3.3	420
10	130

Termination charge current programmed

The battery charge Termination current threshold (IBF) is programmed by connecting a resistor RBF from the IBF pin to GND:

$$I_{BF} = R_{ISET} \times I_{BAT} / R_{BF}$$

A charge cycle is terminated when the charge current falls to IBF programming threshold. The open-drain pin CHRG is used to indicate charging status. When the battery full condition is reached or any other condition prevents the charger from charging, CHRG will become a High impedance pin.

Battery Temperature Detection

The NTC function for the LP28013 is designed to follow the new JEITA temperature standard for Li-Ion. There are now three thresholds, 60°C, 10°C, and 0°C. Normal operation occurs between 10°C and 60°C. If between 0°C and 10°C the charge current level is cut in half. Above 60°C or below 0°C the charge is disabled.

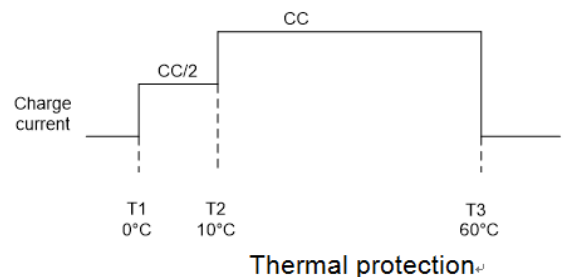

The NTC feature is implemented using an internal 48µA current source to bias the thermistor connected from the NTC terminal to GND(designed for use with a 10k NTC β = 3370 [SEMITEC 103AT-2 or Mitsubishi TH05-3H103F]). If NTC feature is not needed, a fixed 10kΩ can be placed between NTC and GND to allow normal operation. Since the INTC current is fixed along with the temperature thresholds, it is not possible to use thermistor values other than the 10k NTC (at 25°C).



Automatic Recharge

Once the charge cycle is terminated, the LP28013 continuously monitors the voltage on the BAT pin. A charge cycle restarts when the battery voltage falls below 4.05V (which corresponds to approximately 80% to 90% battery capacity). This ensures that the battery is kept at or near a fully charged condition and eliminates the need for periodic charge cycle initiations.

Enable Function

The LP28013 features an enable/disable function. An input “Low” signal at EN pin or if this pin is floating will enable the IC. To assure the charger will switch on, the EN turn on control level must below 0.4 volts. The charger IC r will go into the shutdown mode when the voltage on the EN pin is greater than 2.4 volts. If the enable function is not needed in a specific application, it may be tied to GND or floating to keep the charge IC in a continuously on state.

Charge Status Indicator (CHAG & PG)

After application of a 5V source, the input voltage rises above the U_{VLO} and sleep thresholds ($V_{IN} > V_{BAT} + V_{DT}$), but is less than OVP ($V_{IN} < V_{OVP}$), then the PG turns on and provides a low impedance path to ground.

CHRG has two different states: strong pull-down (~5mA) and high impedance. The strong pull-down state indicates that the LP28013 is in a charge cycle. Once the charge cycle has terminated, the pin state is determined by under voltage lockout conditions. High impedance indicates that the LP28013 is in under voltage lockout mode: either V_{IN} is less than 100mV above the BAT pin voltage or insufficient voltage is applied to the V_{IN} pin.

Function	CHRG
Charging	Low
Charge END	High

Function	PG
$V_{IN} < U_{VLO}$	High
$U_{VLO} < V_{IN} < OVP$	Low
$OVP < V_{IN}$	High

Thermal Limiting

An internal thermal feedback loop reduces the I SET ramed charge current if the die temperature attempts to rise above a preset value of approximately 125°C. This feature protects the LP28013 from excessive temperature and allows the user to push the limits of the power handling capability of a given circuit board without risk of damaging the LP28013. The charge current can be set according to typical (not Worst-case) ambient temperature with the assurance that the charger will automatically reduce the current in worst-case conditions.

Power Dissipation

The conditions that cause the LP28013 to reduce charge current through thermal feedback can be approximated by considering the power dissipated in the IC. Nearly all of this power dissipation is generated by the internal MOSFET calculated to be approximately:

$$P_D = (V_{IN} - V_{BAT}) \cdot I_{BAT}$$

where PD is the power dissipated, V_{IN} is the input supply voltage, V_{BAT} is the battery voltage and I_{BAT} is the charge current. The approximate ambient temperature at which the thermal feedback begins to protect the IC is:

$$T_A = 125^\circ\text{C} - PD \cdot \theta_{JA}$$



Packaging Information

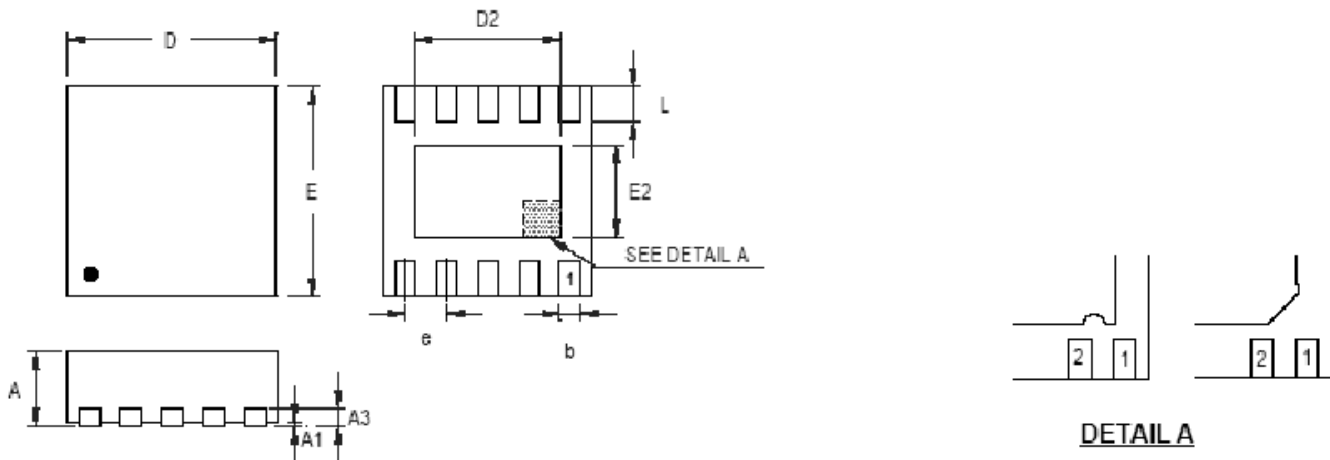

DETAIL A

Pin #1 ID and Tie Bar Mark Options

Note : The configuration of the Pin #1 identifier is optional, but must be located within the zone indicated.

Symbol	Dimensions in millimeters		Dimensions in inches	
	Min	Max	Min	Max
A	0.700	0.800	0.028	0.031
A1	0.000	0.050	0.000	0.002
A3	0.175	0.250	0.007	0.010
b	0.180	0.300	0.007	0.012
D	2.950	3.050	0.116	0.120
D2	2.300	2.650	0.091	0.104
E	2.950	3.050	0.116	0.120
E2	1.500	1.750	0.059	0.069
e	0.500		0.020	
L	0.350	0.450	0.014	0.018